

SPEED LOGS & ECHO SOUNDERS

**SIMPLIFYING INSTALLATION AND
MINIMIZING COST**



TAKING SAFETY SERIOUSLY IS OUR DRIVING FORCE.

Consilium is a well established company within the marine industry, with a long experience from developing **innovative and high quality products**, such as the **SAL speed logs** and **echo sounders**.

When choosing a Consilium product you will get a type approved product together with a **life time commitment** from an advisory partner, providing **first class support** and **excellent service**.

CHOOSE FROM A COMPREHENSIVE RANGE OF SAL SPEED LOGS

Consilium has thoughtfully extended the speed log product range to ensure the ability to provide the right solution, regardless of if you are building a new ship or working on a retrofit. Let us be your advisory partner, providing a high quality product that fulfils your needs and values.

Modern SAL speed logs use the ultrasonic measuring principle and are therefore referred to as Doppler type speed logs.

CONSILIUM SPEED LOG SELECTION CERTIFIED BY THE MAJOR CLASSIFICATION SOCIETIES.

Consilium offers a wide selection of speed logs and echo sounders that fulfill all regulations and requirements and the wide selection of SAL speed logs offers both relative and true speed log versions, including the world's first type approved combined speed log and echo sounder system.

SAL speed logs and Echo sounders solutions from Consilium				
Solution	Water track	Bottom track	Docking log	Echo sounder
SAL R1a				
SAL R1E				
SAL T3				
SAL T2+				
SAL T2E				
Echo sounder E1				
Echo sounder E2				

*All systems are approved for vessels up to 50,000 GT
The T2+, T2E, E1 and E2 are also approved for vessels over 50,000 GT*

TYPE APPROVED FOR VESSELS UPTO 50.000 GT

Consilium's SAL R1a is a one-axis relative speed log, measuring speed through water in longitudinal direction ahead and astern.

The SAL R1E is a cost efficient solution that fulfills the SOLAS regulation for both speed log and echo sounder (E1 version).

The SAL T3 solution combines the speed log features with echo sounding, measuring longitudinal relative speed through water as well as two-axis true speed over ground.

TYPE APPROVED FOR ALL VESSELS

Consilium's SAL T2E is a cost efficient solution with both speed log (T2+) and echo sounder (E2). It has dual echo sounders, speed through water (STW) and speed over ground (SOG) speed logs, small bottom parts and only requires two hull penetrations. The SAL T2+ transducer also delivers approved depth information (150 kHz sounder) to the E2 echo sounder display.

The SAL T2+ solution is a unique docking and dual axis speed log. The SAL T2+ measures longitudinal relative speed through water (STW) as well as two-axis true speed over ground (SOG). The transducer has both a separate device for STW and a separate device for SOG and therefore requires only one hull penetration.



BENEFITS WITH A SOLUTION FROM CONSILIUM

- A minimum of hull penetrations
- Fulfils the new SOLAS 2014 MSC.334(90)
- Small transducers
- Cost efficient solutions
- Easy to install
- No divers needed during retrofit
- Low maintenance
- High quality
- High accuracy by correlation principle
- Non reliant on easily interfered satellite systems
- Flexible retrofit solutions
- 24/7 worldwide support



A complete R1a system

System overview of SALT2E

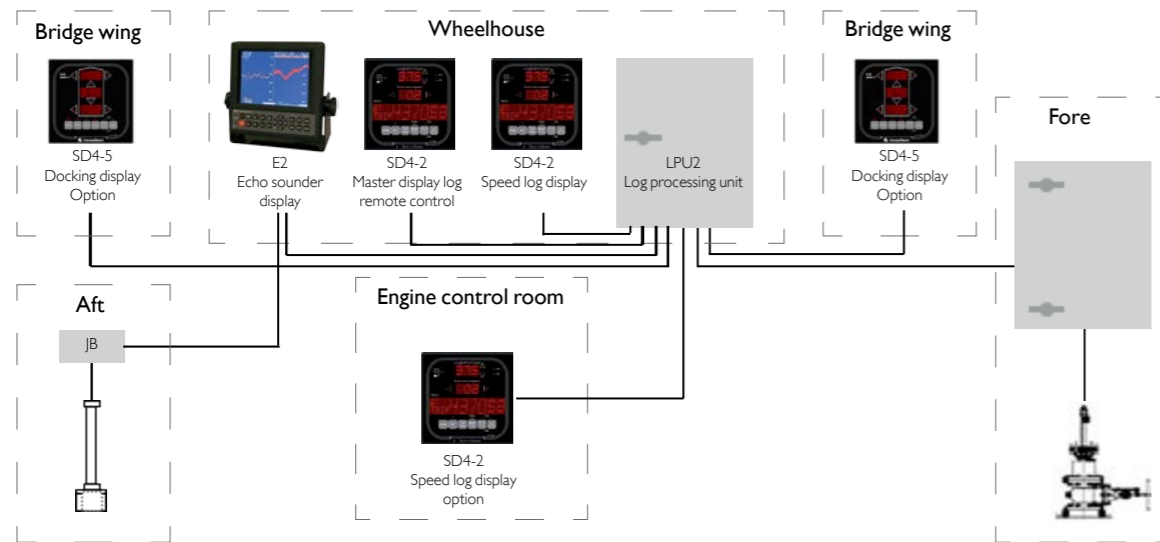

Example of a full docking log and double echo sounder functionality with the unique SALT2+ transducer in the bow for STW, SOG and navigational depth and the E2 echo sounder in the aft. Note: only two hull penetrations needed.



SD4-2: SOG and STW



SD4-3: STW



SD4-4: General



SD4-5: Docking



The unique SALT2+ transducer



The SAL R1E transducers mounted in the same small sea valve.

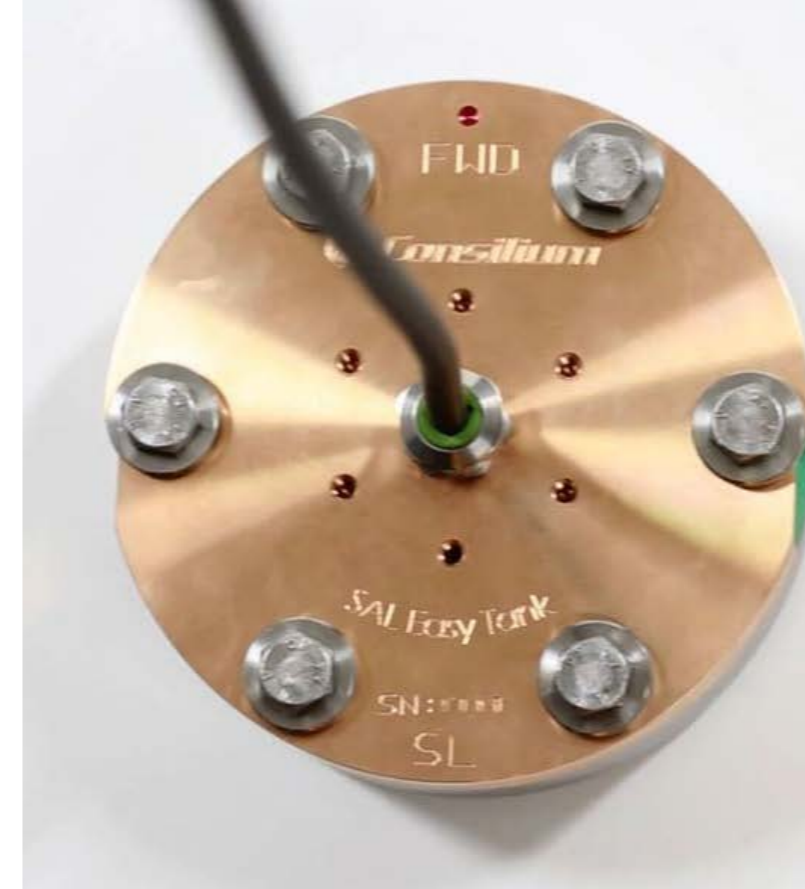

SAL R1A EASY TANK THE EASIEST SOLAS SPEED LOG TO INSTALL

SAL R1a Easy Tank is the fourth generation acoustic correlation SAL speed log for measuring relative speed – speed through water (STW). The speed log is designed to meet requirements as specified by authorities and shipowners. Its performance exceeds the various IMO specifications and has proven reliability in many thousand installations worldwide.

GENERAL DESCRIPTION

The basic version of SAL R1a includes bottom arrangements, transducer, and electronics unit, all mounted in the bow area. SD displays as selected are installed in the bridge area.

The unit provides serial output signal according to IEC 61162-1/NMEA 0183 as well as 200 pulses per NM and analogue voltage output. Therefore it can be integrated and displayed in many different ways and systems.

- The electronics are mounted on a circuit board enclosed in a splash proof steel box. Cable glands are provided in the bottom plate of the box.
- Bottom arrangement with EasyTank is available for both aluminium and steel hull construction.
- Watertight cable enables installation in wet and demanding environments
- High watertight integrity and resistance to damage.

MAIN FEATURES

- Closed ended installation - no need for water tight compartment or piping above sealine.
- Easy to install, with only a few mechanical parts and light weight bottom parts. The transducer mounting is made from the inside of the hull.
- Safe due to the rugged mechanical design and water tight cable.
- Pressure tested and approved according to PN16 (24 bar, 240 m).
- High performance because of the proven Acoustic Correlation technology.
- Space saving with the small and compact bottom parts
- Easy set-up and calibration procedures from the bridge SD4 displays.
- Flexible calibration allows very accurate reading over the speed range.

INSTALLATION IN THREE STEPS:



CONSILIUM'S UNIQUE SOLUTIONS

Consilium's SAL R1E, SALT2+ and SALT2E are unique solutions, requiring a minimized number of hull penetrations, always fulfilling the SOLAS MSC.334(90) requirement.



- Echo Sounder
- Speed through water
- Speed over ground

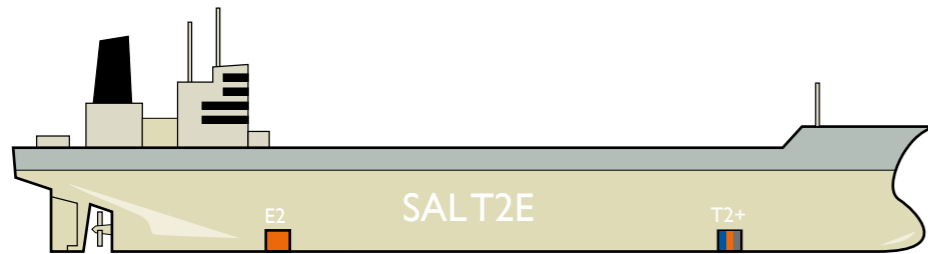
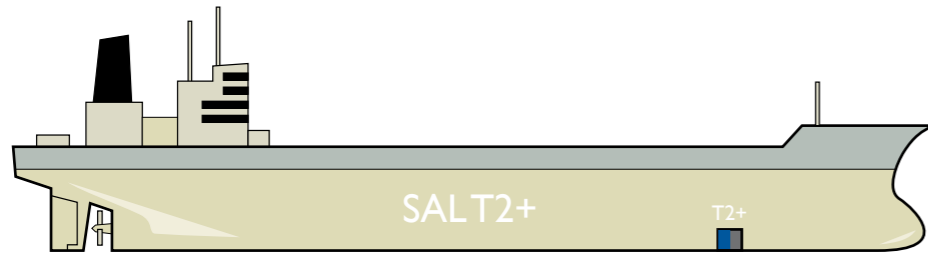

TRADITIONAL SOLUTIONS

Traditional solutions require between two and four hull penetrations.

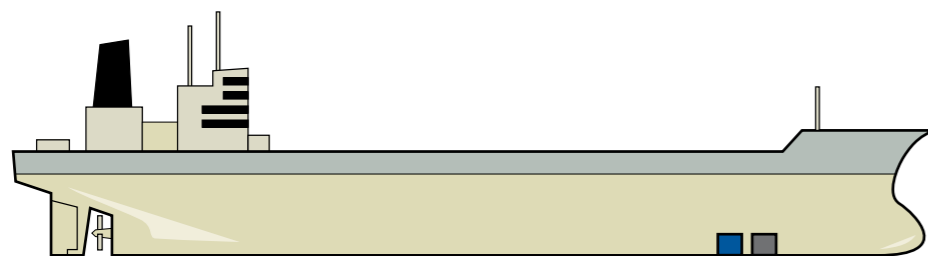

- Echo Sounder
- Speed through water
- Speed over ground

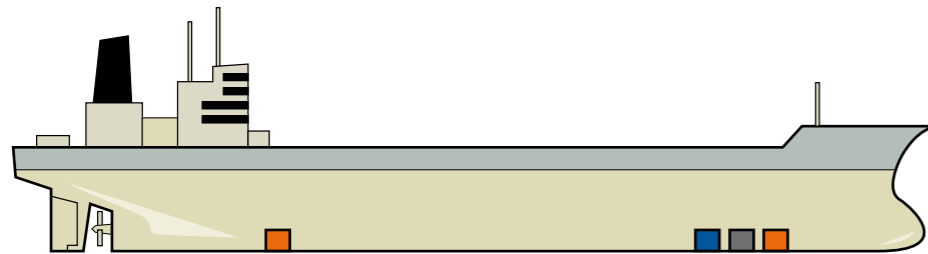

CONSILIUM NAVIGATIONAL ECHO SOUNDER SELECTION

Consilium offers two types of reliable and low cost navigational echo sounders, the E1 and the E2. They are both easy to install and to operate and have been approved according to MED and found to be in compliance with IMO regulations. The E1 echo sounder is included in the SAL R1E package and the E2 in the SALT2E package.

Technical information

SAL speed logs - Speed Through Water (STW)	
Speed range:	±50 knots sensed water speed
Speed inaccuracy:	0.1 knot or 1.0% whichever is greater
Distance inaccuracy:	<±1.0% of travelled distance in water
Minimum water depth:	3 m below transducer
SAL speed logs - Speed Over Ground (SOG)	
Speed range:	±40 knots in any direction
Depth range:	2-250 m below transducer
Speed inaccuracy:	0.1 knot or 1% whichever is greater
Travelled Distance Inaccuracy:	2-10 NM ±0.2%, 10-50 NM ±0.1%, >50 NM ±0.05%
E1 - single-frequency navigation sounder	
Transducer frequencies:	50 or 200 kHz (to be user-specified)
Screen:	5.7" LED-backlit LCD, daylight viewing
Depth ranges:	5 to 1000m in 8-range steps
Transmit power:	600W RMS
Data storage:	Up to 12 hours
E2 - compact high-end, two unit model	
Transducer frequencies:	50 kHz + 200 kHz
Display:	8" VGA TFT-LCD, daylight viewing
Depth ranges:	5 to 1000m in 8-range steps
Transmitter:	1 kW max
Data storage:	Up to 24 hours



Echo sounder E2 display



Echo sounder E1 display

FOR ALL THOSE MOMENTS **WHEN SAFETY MATTERS**

Consilium is a producer of safety technologies for the marine, oil and gas, transport and building sectors. Our commitment goes beyond the products:

We protect the lives of mothers and fathers, sisters and brothers, colleagues and friends. With representation in more than 55 countries in all time zones, we are always close to you.



marinesales@mackaymarine.com
+1 281 479 1515

service@mackaymarine.com
+1 281 478 6245