

SmartFind S5A AIS SART

The SmartFind S5A AIS SART is a manual deployment survival craft AIS Search and Rescue Transmitter (AIS SART), intended for use on life rafts or survival craft. It meets IMO SOLAS requirements and is a replacement for legacy radar SARTs.



SmartFind S5A AIS SART

Compact and easy to both operate and deploy, the SmartFind S5A AIS SART is a transponder packed inside a quick release carry off bag, that allows a survival crafts location to be identified by rescue authorities and nearby AIS equipped vessels.

The SmartFind S5A transmits survivor information, including structured alert messages, GPS position information and serialised identity number. Once activated the SmartFind S5A AIS SART transmits continually for a minimum of 96 hours and inbuilt high precision GNSS receiver provides accurate position information to assist in the detection of the survival crafts' location.

Whether wall mounted in the ships bridge or packed inside a survival craft, the highly visible and buoyant carry case affords maximum protection.

- Internationally approved
- Ship or Survival craft options
- Waterproof to 10m
- Buoyant/floats
- Rugged, compact and lightweight
- Minimum 96 hour operational battery life
- 6 year battery life
- Visual indication of operation
- Built-in test facility
- Mounting options — Internal/External
- Transmits GPS coordinates
- Interoperability with AIS Users
- Telescopic Mounting Pole included
- Comes with protective carry off bag

Technical Specifications

Beacon Specification Standards applied

APPLICABLE STANDARDS	IEC 61097-14 Ed.1 (2010)
	IEC 60945 Ed. 4 (2002) incl. Corrigendum 1 (2008)
	IMO Resolution A.694 (17)
	IMO Resolution MSC.246 (83)
	IMO Res. MSC.302 (87)*

ITU-R M.1371-5 (2014)
 *: This covers Bridge Alert Management and it is not applicable for AIS

VHF TRANSMITTER	Operating Frequency	AIS 1, 161.975MHz AIS 2, 162.025MHz	
	Data Rate	9,600bps	
	Bandwidth	25 KHz	
	Power Output	1W EIRP	
	AIS Message Type	Message 1, Message 14	
	Modulation	GMSK	
	Antenna	Integrated by PCB	
GNSS RECEIVER	Receiving Channels	48 channels	
	Acquisition Sensitivity	(-)159 dBm	
	Tracking Sensitivity	(-)159 dBm	
	Position Accuracy	< 2.5 m Autonomous & SBAS	
BATTERY	Type	Primary Lithium (not rechargeable)	
	Operating Life	96 hours minimum	
	Storage Service	6 years Replaceable	
CARRY & MOUNTING	Carry Bag		
	Wall Mount		
ENVIRONMENT	Operating temperature	-20°C to +55°C	
	Storage temperature	-30°C to +70°C	
	Waterproof	Immersion to 10m	
	Buoyancy	Floats	
	Exterior Finish	Highly visible Yellow	
	Compass safe distance	Standard Magnetic	— 0.60m
		Steering Magnetic	— 0.40m

PHYSICAL	Max Diameter (Main Body)	70 mm	
	Length (Main Body)	300 mm	
	Weight (Main Body)	283g (Battery included)	
	Length (Pole)	1050mm (Extended)	
	Weight (Pole)	300g	
	Total Weight (Storage Package)	1.08kg	

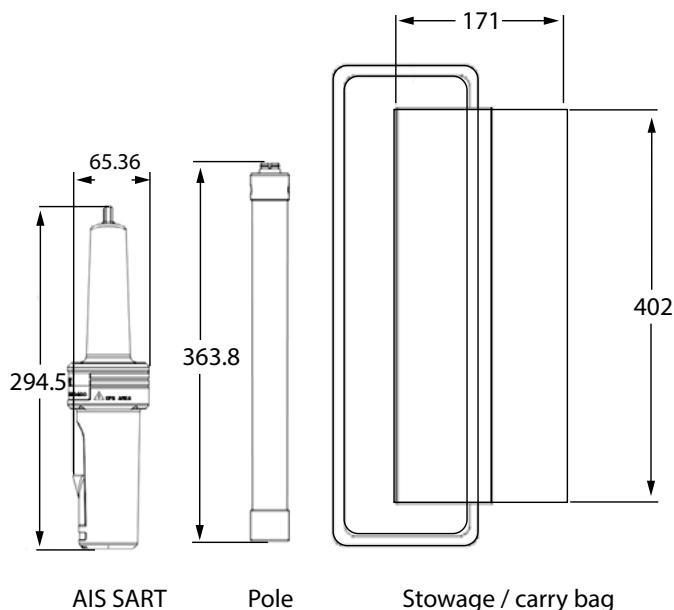

McM O8.18 Iss1