



**LT-4200L SATELLITE  
COMMUNICATIONS SYSTEM**  
**IRIDIUM CERTUS® 200 LANDMOBILE**  
(FIXED INSTALLATION)

## FIXED INSTALLATION



## LT-4200L IN SHORT

- 3 x Voice Channels (high quality)
- IP-data: 176 kbps (up) / 176 kbps (down)
- High-performance GNSS/GPS receiver
- Single antenna cable solution (up to 150 m)
- Support for external SIP PABX and SIP handsets (up to 8)
- Firewall and user authentication for high level of security
- Web server for configuration and maintenance

## PRODUCT DESCRIPTION

The LT-4200L Satellite Communications System (Iridium Certus® 200) is a LandMobile satellite communication product from Lars Thrane A/S. The LT-4200L system is designed for fixed installation only. The LT-4200L system has voice and data capabilities with 100% global coverage provided by the Iridium® Network. The LT-4200L system consists of a control unit, antenna unit, handset, and cradle. The LT-4200L system offers 3 high quality voice channels, and IP-data 176 kbps (up) / 176 kbps (down), making it the perfect satcom communication product for any fixed installation.

## PRODUCT FEATURES

### VOLUME CONTROL

Handset speaker volume control button

### RINGER

Incoming call ringer

### MICROPHONE

High-quality microphone

### COLOR DISPLAY

Large 4.3" TFT display supporting brightness adjustment and day/night mode themes

### KEYPAD

Responsive keypad with brightness adjustments

### AUDIO SPEAKER

Audio speaker supporting key beep, voice prompt, and alarms

### FUNCTIONAL KEYS

Functional keys; off-hook, on-hook, navigation, and soft keys

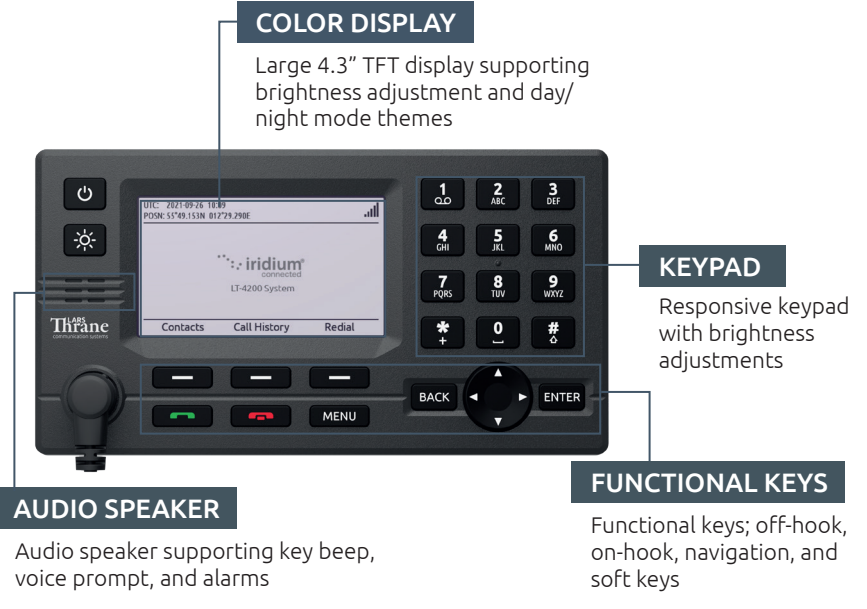

# INTERFACES

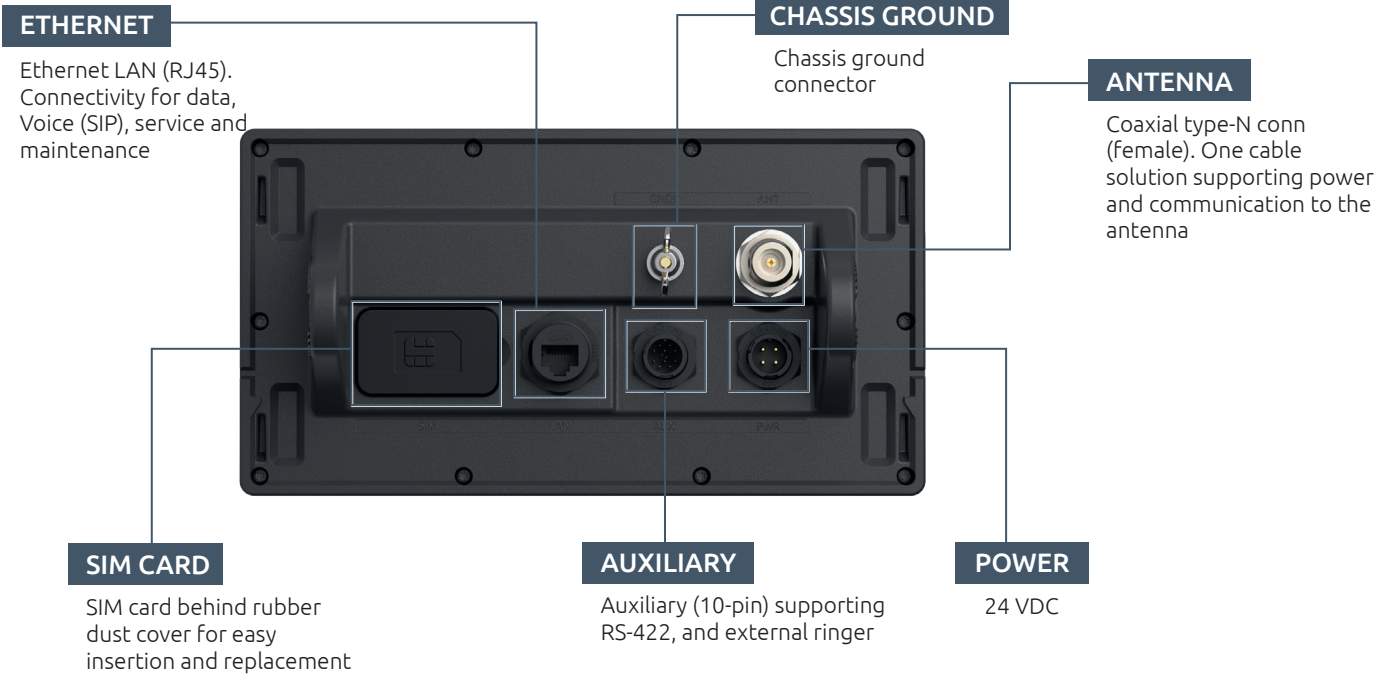

# INSTALLATION OPTIONS

## ANTENNA MOUNTING KITS



Pole Mount (2.0", Ø53.0mm, A4 Stainless), Antenna Unit

## CONTROL UNIT MOUNTING KITS



Bracket Mount Control Unit



Flush Mount Control Unit

# SYSTEM CONFIGURATION

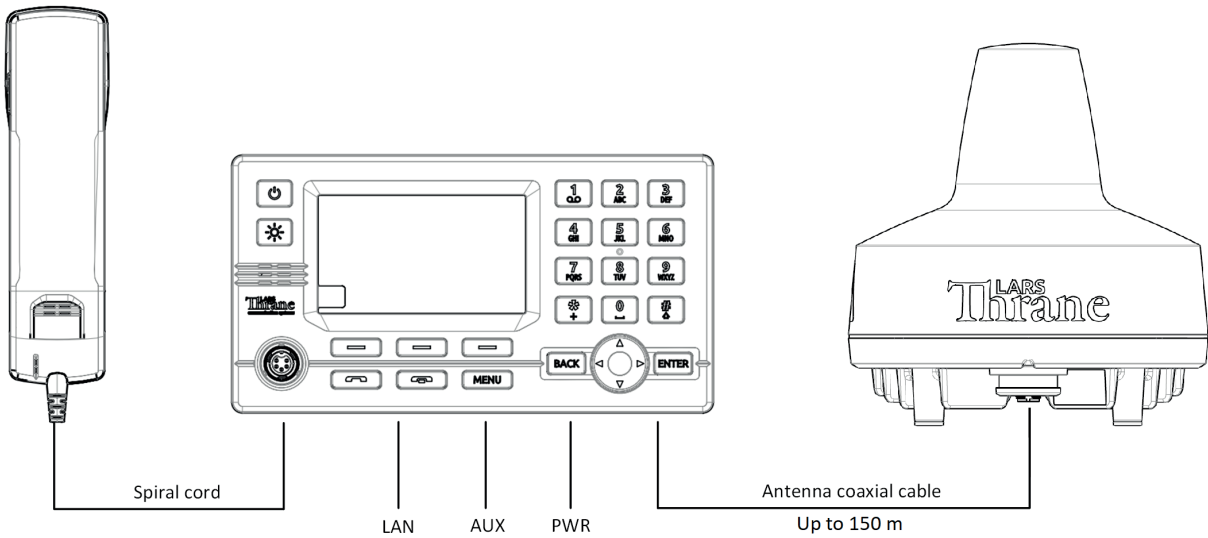

## SPECIFICATIONS

### LT-4200L SATELLITE COMMUNICATIONS SYSTEM

Certification & standards	CE, FCC, ISED, RED, RoHS 2, Iridium®
Vibration, operational	IEC 60945
Vibration, shock	Half sine 20 g/11 ms
Compass Safe Distance, std.	0.3 - 1.4 m (1.0 - 4.6 ft)
Compass Safe Distance, steer.	0.3 - 0.9 m (1.0 - 3.0 ft)
Power consumption: Transmit, max	154 W
Power consumption: Receive	24 W

### LT-4210 Control Unit

Weight	0.67 kg (1.48 lbs)
Dimensions	224.0 x 120.0 x 70.0 mm (8.82 x 4.72 x 2.76 in)
Temperature, operational	-15°C to +55°C (+5°F to +131°F)
IP rating, dust and water	IP32
Interfaces	Ethernet, auxiliary, DC input, chassis ground Antenna Unit (N conn.), handset, SIM card
Input power	24 VDC (8 A)

### LT-3120 Handset Unit

Weight (handset + wire)	0.30 kg (0.66 lbs)
Dimensions	52.8 x 208.8 x 38.2 mm (2.08 x 8.22 x 1.50 in)
Temperature, operational	-15°C to +55°C (+5°F to +131°F)
IP rating, dust and water	IP32

### LT-4230L Antenna Unit

Weight	3.70 kg (8.16 lbs)
Dimensions	238.7 x Ø 224.6 mm (9.40 x Ø 8.84 in)
Temperature, operational	-40°C to +55°C (-40°F to +131°F)
IP rating, dust and water	IP67
Interfaces	Control Unit (N conn.)
Antenna communication cable	Coaxial cable, up to 150 m (500 ft)
Warranty	2 years
Maintenance	None

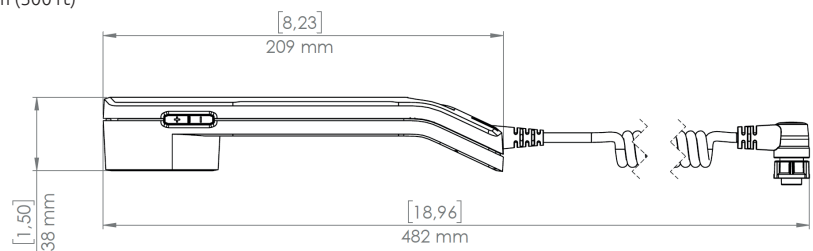
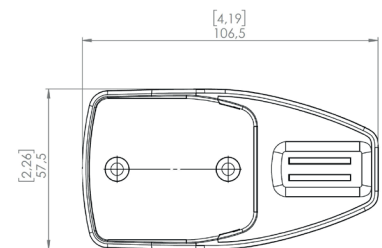
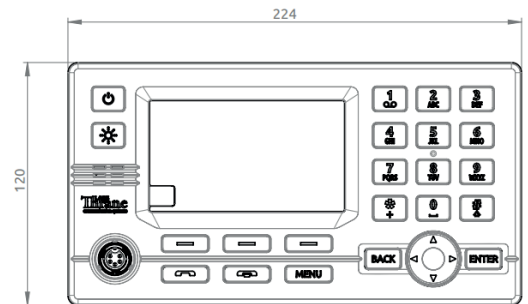
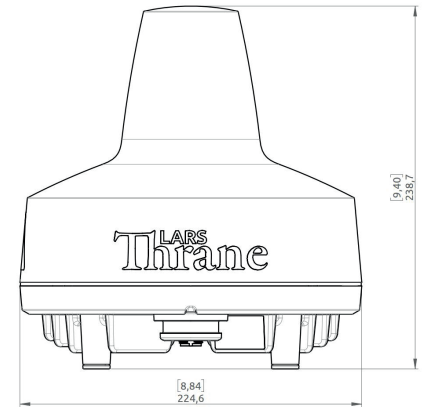

### IN THE BOX

LT-4210 Control Unit	P/N: 51-102664
LT-3120 Handset	P/N: 51-100988
LT-3121 Cradle	P/N: 51-101181
LT-4230L Antenna Unit (LandMobile)	P/N: 51-103149
Bracket Mount, Control Unit	P/N: 91-100771
Power Cable, 3m	P/N: 91-102118
User & Installation Manual	P/N: 95-102665

### ACCESSORIES

Flush Mount, Control Unit	P/N: 91-100772
Pole Mount (2.0" pipe, Ø53.0mm, A4 Stainless), Antenna Unit	P/N: 91-102967
Auxiliary Cable, 3m	P/N: 91-100768
Coaxial Cable Ø10.3mm (up to 150m)	
Crimping Tool for Coaxial Cable Ø10.3mm	



Lars Thrane A/S  
Skovlytoften 33  
DK-2840 Holte, Denmark  
Phone: +45 88 30 10 00 Fax: +45 88 30 10 09  
Email: sales@thrane.eu  
CVR DK-36042443  
www.thrane.eu